

**MOTOROLA**



*digital dna*<sup>™</sup>

---

*Semiconductor Products Sector  
Product Summary Rev 1.0*

## **MC68HC908EY16**

The MC68HC908EY16 microcontroller is the first in a family of high performance 8-bit microcontrollers targeted at LIN based solutions and general market applications.

Offering 16K bytes of high performance Flash memory, future family derivatives will provide full pin compatibility and a range of Flash based program memories.

This document provides an overview of the features of the MC68HC908EY16. Further details are available in the advance information data book which is available on request.

---

© Motorola, Inc., 2001

## 1 Introduction

---

The MC68HC908EY16 is a member of the low-cost, high-performance M68HC08 Family of 8-bit microcontroller units (MCUs). All MCUs in the family use the enhanced M68HC08 central processor unit (CPU08) and are available with a variety of modules, memory sizes and types, and package types.

## 2 Features

---

For convenience, features have been organized to reflect:

- Standard features of the MC68HC908EY16
- Features of the CPU08

Standard features of the MC68HC908EY16 include:

- High-performance M68HC08 architecture optimized for C-compilers
- Fully upward-compatible object code with M6805, M146805, and M68HC05 Families
- 8-MHz internal bus frequency at 5V, 4MHZ at 3V
- Internal oscillator requiring no external components:
  - Software selectable bus frequencies
  - 25 percent accuracy with trim capability to 2 percent
  - Clock monitor
  - Option to allow use of external clock source or external crystal/ceramic resonator
- 15,872 bytes of on-chip FLASH memory with in-circuit programming
- FLASH program memory security<sup>1</sup>
- 512 bytes of on-chip random-access memory (RAM)

- Low voltage inhibit (LVI) module with software selectable trip points for 5V and 3V operation.
- Internal clock generator module (ICG)
- Two 16-bit, 2-channel timer (TIMA and TIMB) interface modules with selectable input capture, output compare, and pulse-width modulation (PWM) capability on each channel
- 8-channel, 10-bit successive approximation analog-to-digital converter (ADC)
- Enhanced serial communications interface module (ESCI) for local interconnect network (LIN) connectivity
- Serial peripheral interface (SPI)
- Timebase Module (TBM)
- 5-bit keyboard interrupt (KBI) with wakeup feature
- 24 general-purpose input/output (I/O) pins
- External asynchronous interrupt pin with internal pullup (IRQB)
- System protection features:
  - Optional computer operating properly (COP) reset
  - Illegal opcode detection with reset
  - Illegal address detection with reset
- 32-pin quad flat pack (QFP) package
- Low-power design; fully static with stop and wait modes
- Internal pullups on IRQB and RSTB to reduce customer system cost
- Standard low-power modes of operation:
  - Wait mode
  - Stop mode
- Master reset pin (RSTB) and power-on reset (POR)

---

1. No security feature is absolutely secure. However, Motorola's strategy is to make reading or copying the FLASH difficult for unauthorized users.

- BREAK module (BRK) to allow single breakpoint setting during in-circuit debugging
- Higher current source capability on nine port lines for LED drive (PTA6/ $\overline{SS}$ , PTA5/ $\overline{SPSCK}$ , PTA4/ $\overline{KDB4}$ , PTA3/ $\overline{KBD3}$ , PTA2/ $\overline{KBD2}$ , PTA1/ $\overline{KBD1}$ , PTA0/ $\overline{KBD0}$ , PTC1/MOSI, and PTC0/MISO)

Features of the CPU08 include:

- Enhanced HC05 programming model
- Extensive loop control functions
- 16 addressing modes (eight more than the HC05)
- 16-bit index register and stack pointer
- Memory-to-memory data transfers
- Fast  $8 \times 8$  multiply instruction
- Fast  $16 \div 8$  divide instruction
- Binary-coded decimal (BCD) instructions
- Optimization for controller applications
- Third party C language support

### 3 MCU Block Diagram

---

**Figure 1** shows the structure of the MC68HC908EY16.

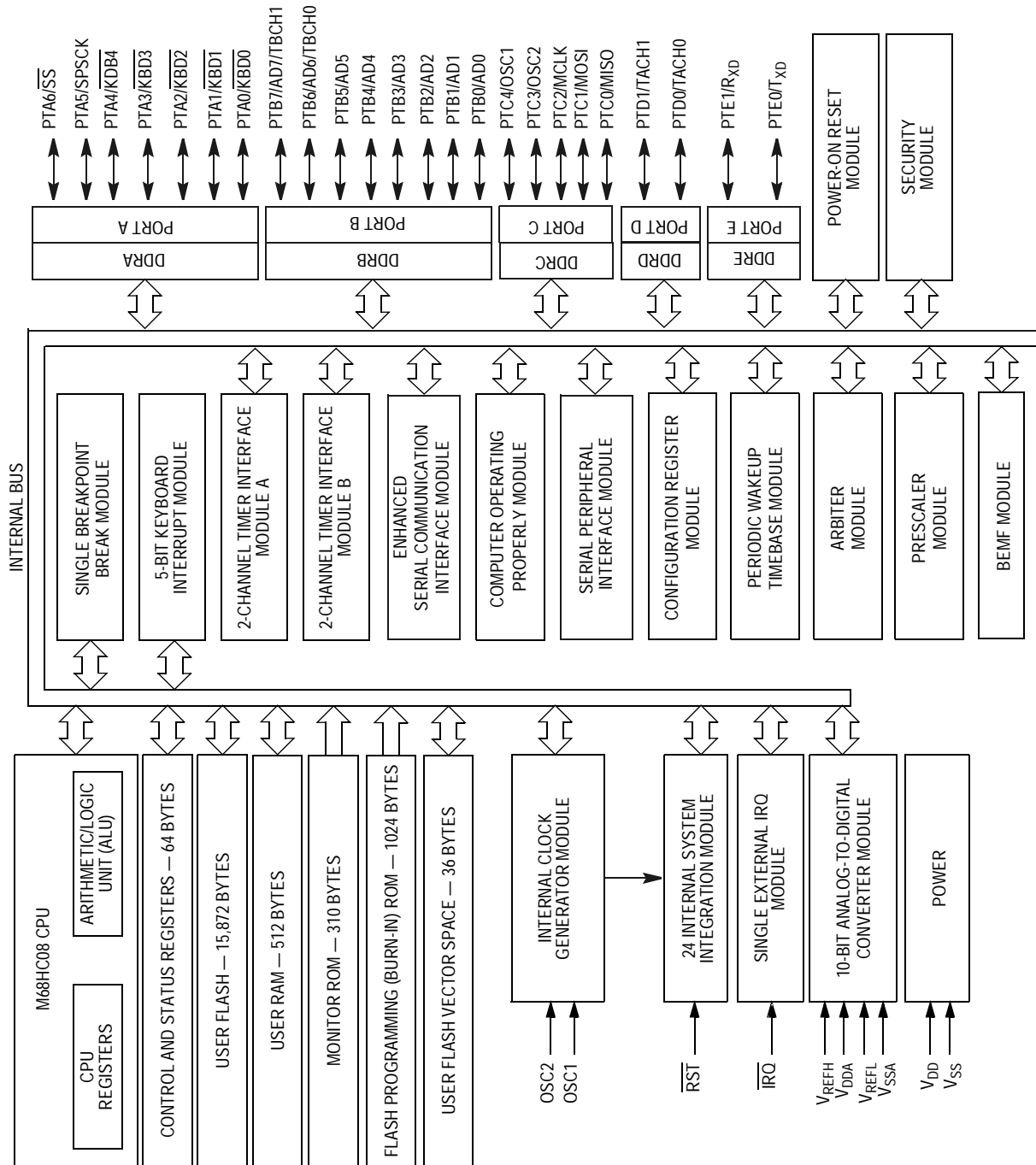
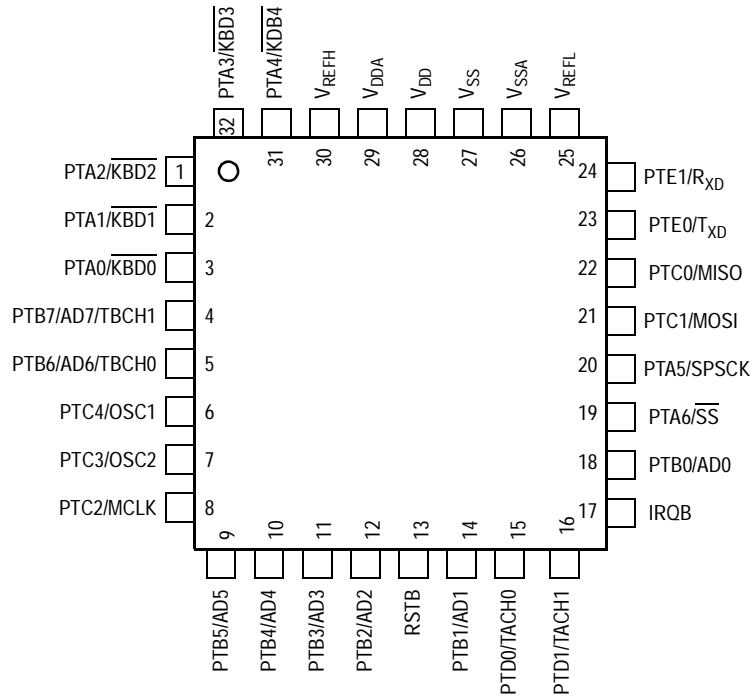

Figure 1. MCU Block Diagram

## 4 Pin Assignments

Figure 2 shows the pin assignments for the MC68HC908EY16.



**Figure 2. Pin Assignments**

## 5 Pin Functions

---

Descriptions of the pin functions are provided here.

### 5.1 Power Supply Pins ( $V_{DD}$ and $V_{SS}$ )

$V_{DD}$  and  $V_{SS}$  are the power supply and ground pins. The MCU operates from a single power supply.

Fast signal transitions on MCU pins place high, short-duration current demands on the power supply. To prevent noise problems, take special care to provide power supply bypassing at the MCU as **Figure 3** shows. Place the C1 bypass capacitor as close to the MCU as possible. Use a high-frequency-response ceramic capacitor for C1. C2 is an optional bulk current bypass capacitor for use in applications that require the port pins to source high current levels.

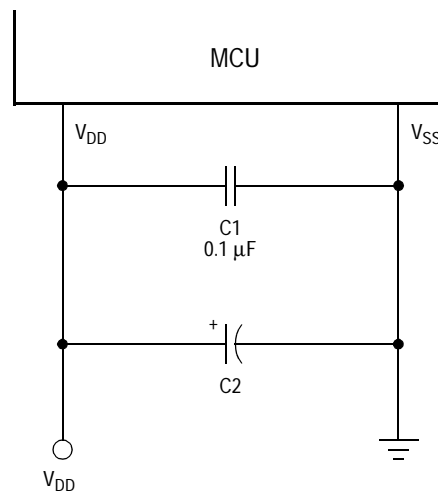

Note: Component values shown represent typical applications.

**Figure 3. Power Supply Bypassing**

### 5.2 Oscillator Pins (PTC4/OSC1 and PTC3/OSC2)

The OSC1 and OSC2 pins are available through programming options in the configuration register. These pins then become the connections to an external clock source or crystal/ceramic resonator.

When selecting PTC4 and PTC3 as I/O, OSC1 and OSC2 functions are not available.

### 5.3 External Reset Pin (RSTB)

A logic 0 on the RSTB pin forces the MCU to a known startup state. RSTB is bidirectional, allowing a reset of the entire system. It is driven low when any internal reset source is asserted. This pin contains an internal pullup resistor that is always activated, even when the reset pin is pulled low.

### 5.4 External Interrupt Pin (IRQB)

IRQB is an asynchronous external interrupt pin. This pin contains an internal pullup resistor that is always activated, even when the IRQB pin is pulled low.

### 5.5 Analog Power Supply/Reference Pins ( $V_{DDA}$ , $V_{REFH}$ , $V_{SSA}$ and $V_{REFL}$ )

$V_{DDA}$  and  $V_{SSA}$  are the power supply pins for the analog-to-digital converter (ADC). Decoupling of these pins should be as per the digital supply.

**NOTE:**  $V_{REFH}$  is the high reference supply for the ADC.  $V_{DDA}$  should be tied to the same potential as  $V_{DD}$  via separate traces.

$V_{REFL}$  is the low reference supply for the ADC.  $V_{SSA}$  should be tied to the same potential as  $V_{SS}$  via separate traces.



## 5.6 Port A I/O Pins (PTA6/SS, PTA5/SPSCK, PTA4/KDB4–PTA0/KBD0)

Port A input/output (I/O) pins (PTA6/SS, PTA5/SPSCK, PTA4/KDB4, PTA3/KBD3, PTA2/KBD2, PTA1/KBD1, and PTA0/KBD0) are special-function, bidirectional I/O port pins. PTA5 and PTA6 are shared with the serial peripheral interface (SPI). PTA4-PTA0 can be programmed to serve as keyboard interrupt pins.

## 5.7 Port B I/O Pins (PTB7/AD7/TBCH1, PTB6/AD6/TBCH0, PTB5/AD5–PTB0/AD0)

PTB7/AD7/TBCH1, PTB6/AD6/TBCH0, and PTB5/AD5–PTB0/AD0 are special-function, bidirectional I/O port pins that can also be used for ADC inputs. PTB7/AD7/TBCH1 and PTB6/AD6/TBCH0 are special function bidirectional I/O port pins that can also be used for timer interface pins.

## 5.8 Port C I/O Pins (PTC4/OSC1, PTC3/OSC2, PTC2/MCLK, PTC1/MOSI, PTC0/MISO)

PTC4/OSC1–PTC0/MISO are special-function, bidirectional I/O port pins. PTC3/OSC2 and PTC4/OSC1 are shared with the on-chip oscillator circuit through configuration options.

When applications require:

- PTC3/OSC2 can be programmed to be OSC2
- PTC4/OSC1 can be programmed to be OSC1

PTC2/MCLK is software selectable to be MCLK, or bus clock out. PTC1/MOSI can be programmed to be the MOSI signal for the SPI. PTC0/MISO can be programmed to be the MISO signal for the SPI.

## 5.9 Port D I/O Pins (PTD1/TACH1–PTD0/TACH0)

PTD1/TACH1–PTD0/TACH0 are special-function, bidirectional I/O port pins that can also be programmed to be timer pins.

### 5.10 Port E I/O Pins (PTE1/R<sub>XD</sub>–PTE0/T<sub>XD</sub>)

PTE1/R<sub>XD</sub>–PTE0/T<sub>XD</sub> are special-function, bidirectional I/O port pins that can also be programmed to be enhanced serial communication interface (ESCI) pins.

**NOTE:** *Any unused inputs and I/O ports should be tied to an appropriate logic level (either  $V_{DD}$  or  $V_{SS}$ ). Although the I/O ports of the MC68HC908EY16 do not require termination, termination is recommended to reduce the possibility of electro-static discharge damage.*

## 6 Revision History

---

The following table gives a summary of revision changes through the history of this document.

**Table 1. Summary of Changes**

Revision	Section	Description of Change
1.0	2.0	LVI, ICG and TBM added to features list
1.0	2.0	PTA6/ $\overline{SS}$ added to list of pins with high current source capability in features list
1.0	3.0	Block diagram revised
1.0	4.0	Pinout revised
1.0	5.5	Analog power supply pin descriptions revised
1.0	5.6–5.10	Minor changes to wording of port pin descriptions for clarification

# Product Summary

Motorola reserves the right to make changes without further notice to any products herein. Motorola makes no warranty, representation or guarantee regarding the suitability of its products for any particular purpose, nor does Motorola assume any liability arising out of the application or use of any product or circuit, and specifically disclaims any and all liability, including without limitation consequential or incidental damages. "Typical" parameters which may be provided in Motorola data sheets and/or specifications can and do vary in different applications and actual performance may vary over time. All operating parameters, including "Typicals" must be validated for each customer application by customer's technical experts. Motorola does not convey any license under its patent rights nor the rights of others. Motorola products are not designed, intended, or authorized for use as components in systems intended for surgical implant into the body, or other applications intended to support or sustain life, or for any other application in which the failure of the Motorola product could create a situation where personal injury or death may occur. Should Buyer purchase or use Motorola products for any such unintended or unauthorized application, Buyer shall indemnify and hold Motorola and its officers, employees, subsidiaries, affiliates, and distributors harmless against all claims, costs, damages, and expenses, and reasonable attorney fees arising out of, directly or indirectly, any claim of personal injury or death associated with such unintended or unauthorized use, even if such claim alleges that Motorola was negligent regarding the design or manufacture of the part. Motorola and  are registered trademarks of Motorola, Inc. Motorola, Inc. is an Equal Opportunity/Affirmative Action Employer.

## How to reach us:

**USA/EUROPE:** Motorola Literature Distribution; P.O. Box 5405, Denver, Colorado 80217. 1-303-675-2140

**HOME PAGE:** <http://www.mcu.motsp.com/>

**JAPAN:** Motorola Japan Ltd.; SPS, Technical Information Center, 3-20-1, Minami-Azabu, Minato-ku, Tokyo 106-8573 Japan.  
81-3-3440-3569

**ASIA/PACIFIC:** Motorola Semiconductors H.K. Ltd.; Silicon Harbour Centre, 2 Dai King Street, Tai Po Industrial Estate,  
Tai Po, N.T., Hong Kong. 852-266668334

**CUSTOMER FOCUS CENTER:** 1-800-521-6274



**MOTOROLA**

© Motorola, Inc., 2001